

CD Radio Cassette-Corder

Operating Instructions

CFD-G70

Warning

To prevent fire or shock hazard, do not expose the player to rain or moisture.

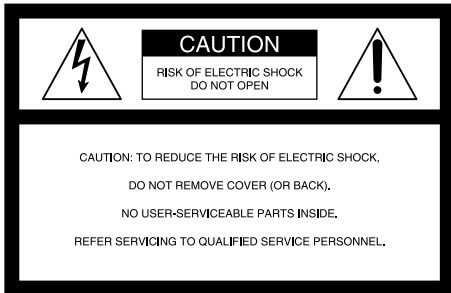

This symbol is intended to alert the user to the presence of uninsulated “dangerous voltage” within the product’s enclosure that may be of sufficient magnitude to constitute a risk of electric shock to persons.



This symbol is intended to alert the user to the presence of important operating and maintenance (servicing) instructions in the literature accompanying the appliance.

CAUTION

The use of optical instruments with this product will increase eye hazard.

WARNING

Do not install the appliance in a confined space, such as a bookcase or built-in cabinet.

For customers in Canada

To prevent electric shock, match wide blade of plug to wide slot, fully insert.

For customers in the United States Information

This equipment has been tested and found to comply with the limits for a Class B digital device, pursuant to Part 15 of the FCC Rules. These limits are designed to provide reasonable protection against harmful interference in a residential installation. This equipment generates, uses and can radiate radio frequency energy and, if not installed and used in accordance with the instructions, may cause harmful interference to radio communications. However, there is no guarantee that interference will not occur in a particular installation. If this equipment does cause harmful interference to radio or television reception, which can be determined by turning the equipment off and on, the user is encouraged to try to correct the interference by one or more of the following measures:

- Reorient or relocate the receiving antenna.
- Increase the separation between the equipment and receiver.
- Connect the equipment into an outlet on a circuit different from that to which the receiver is connected.
- Consult the dealer or an experienced radio/TV technician for help.

You are cautioned that any changes or modifications not expressly approved in this manual could void your authority to operate this equipment.

Owner's Record

The model number is located at the bottom and the serial number is located in the battery compartment.

Record the serial number in the space provided below. Refer to these numbers whenever you call upon your Sony dealer regarding this product.

Model No. CFD-G70

Serial No. _____

Table of contents

Basic Operations

Playing a CD	4
Listening to the radio	6
Playing a tape	8
Recording on a tape	10

The CD Player

Using the display	12
Locating a specific track	12
Playing tracks repeatedly (Repeat Play)	13
Playing tracks in random order (Shuffle Play)	14
Creating your own program (Program Play)	14

The Radio

Presetting radio stations	16
Playing preset radio stations	17

The Audio Emphasis

Selecting the audio emphasis (SOUND/POWER DRIVE WOOFER/ GAME Xpand)	18
---------------------------------------------------------------------------------	----

The Timer

Falling asleep to music	19
-------------------------------	----

Setting Up

Choosing the power sources	20
Connecting a game machine or other optional components	21

Additional Information

Precautions	23
Troubleshooting	24
Maintenance	26
Specifications	27
Index	Back cover

Playing a CD

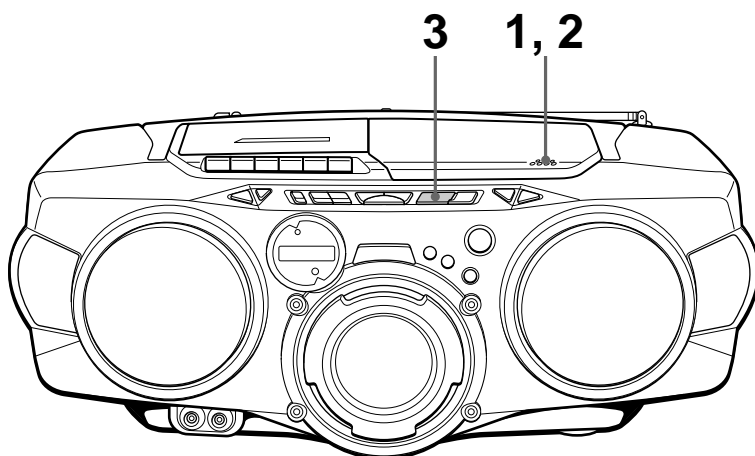

Connect the supplied AC power cord (see page 20).

1

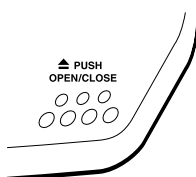

Press ▲PUSH OPEN/CLOSE down to open the CD compartment and place the CD on the CD compartment.

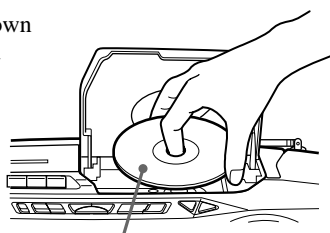

With the label side up

2

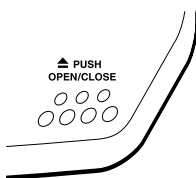

Close the lid of the CD compartment.

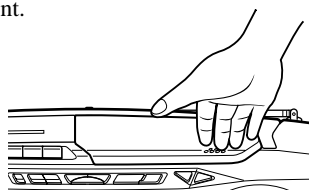

3

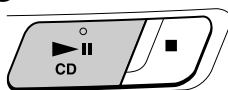

Press ►|| (► on the remote).

The player turns on (direct power-on) and plays all the tracks once.

Display



Track number Playing time

Use these buttons for additional operations

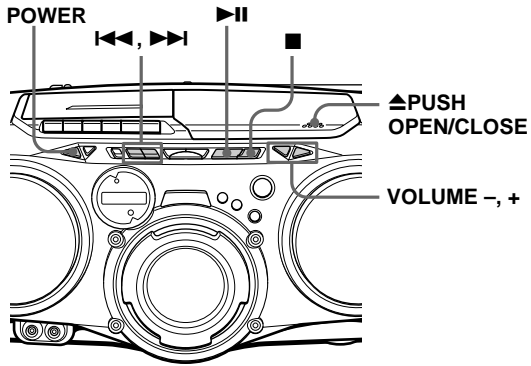

To	Press
adjust the volume	VOLUME +, - (VOL +, - on the remote)
stop playback	■
pause playback	▶ (on the remote) Press the button again to resume play after pause.
go to the next track	▶▶
go back to the previous track	◀◀
remove the CD	▲PUSH OPEN/CLOSE
turn on/off the player	POWER

About CD-Rs/CD-RWs

This player is compatible with CD-Rs/CD-RWs but playback capability may vary depending on the quality of the disc, the recording device and application software.

Listening to the radio

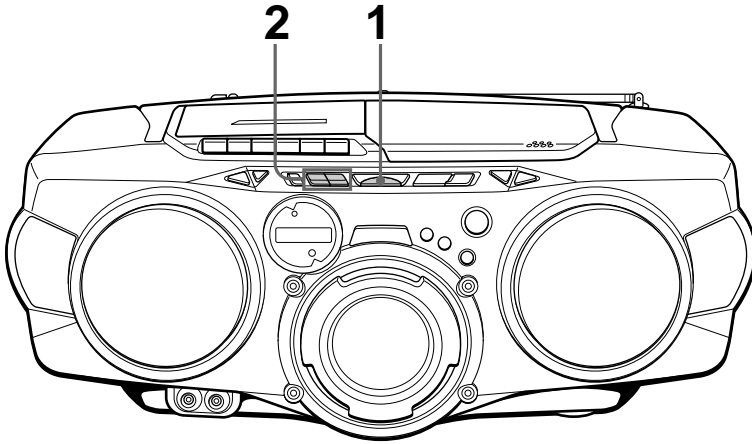

Connect the supplied AC power cord (see page 20).

1

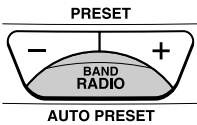

Press RADIO BAND•AUTO PRESET until the band you want appears in the display (direct power-on).

Display

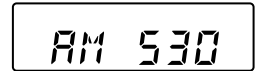

2

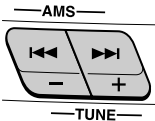

Hold down TUNE + or - until the frequency digits begin to change in the display.

The player automatically scans the radio frequencies and stops when it finds a clear station.

If you can't tune in a station, press the button repeatedly to change the frequency step by step.

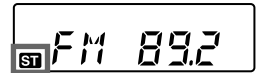

Indicates an FM stereo broadcast

Use these buttons for additional operations

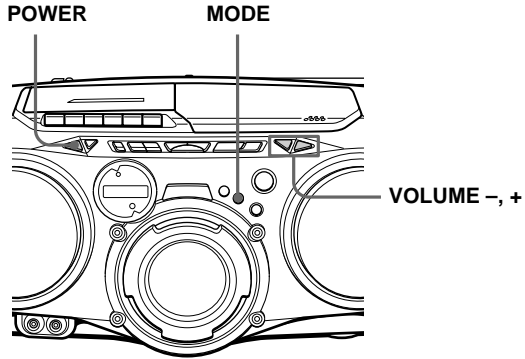

Tip

If the FM broadcast is noisy, press MODE until “Mono” appears in the display and the radio will play in monaural.

To	Press
adjust the volume	VOLUME +, - (VOL +, - on the remote)
turn on/off the radio	POWER

To improve broadcast reception

Reorient the antenna for FM. Reorient the player itself for AM.

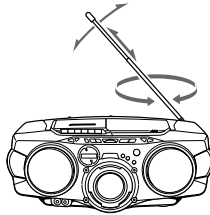

for FM

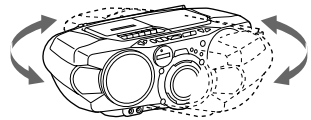

for AM

Playing a tape

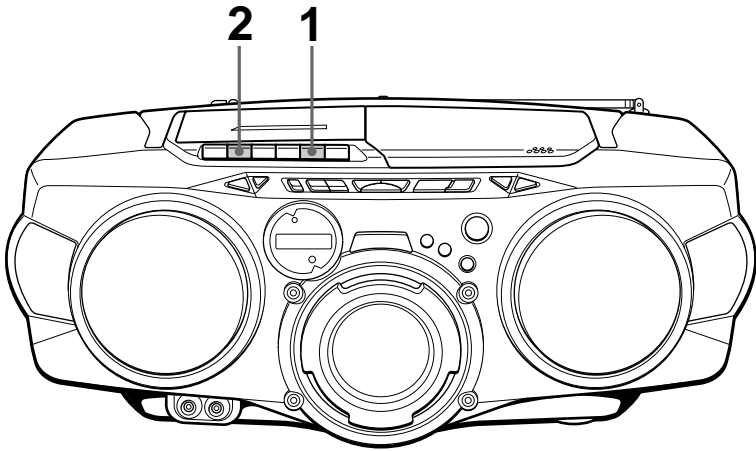

Connect the supplied AC power cord (see page 20).

1

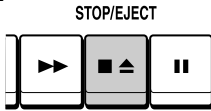

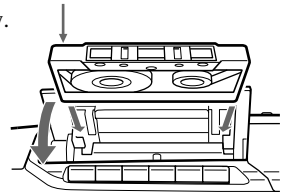

Press  to open the tape compartment and insert a recorded tape. Use TYPE I (normal) tape only. Close the compartment.

With the side you want to play facing upward

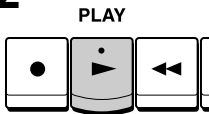

2



Press .

The player turns on (direct power-on) and starts playing.

Display

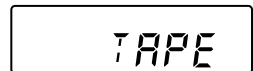

Use these buttons for additional operations

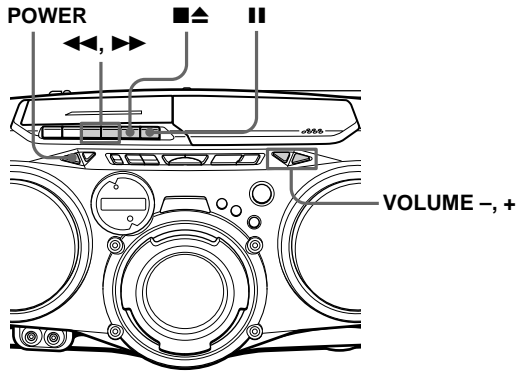

To	Press
adjust the volume	VOLUME +, - (VOL +, - on the remote)
stop playback	■▲
fast-forward or rewind the tape	▶▶ or ◀◀
pause playback	 Press the button again to resume play after pause.
eject the cassette	■▲
turn on/off the player	POWER

Recording on a tape

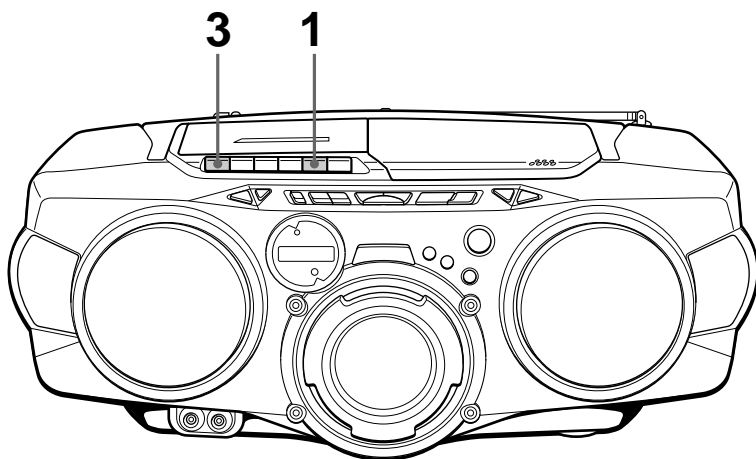

Connect the supplied AC power cord (see page 20).

1

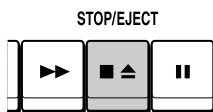

Press  to open the tape compartment and insert a blank tape. Use TYPE I (normal) tape only.

With the side you want to record on facing upward

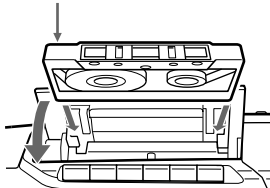

2

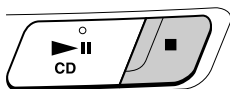

Select the program source you want to record.

To record from the CD player, insert a CD (see page 4) and press  on the CD section.

Display

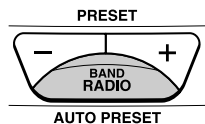
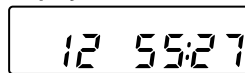

To record from the radio, tune in the station you want (see page 6).

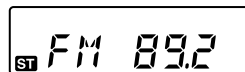

3

REC



Press ● to start recording
(▶ is depressed automatically).

Use these buttons for additional operations

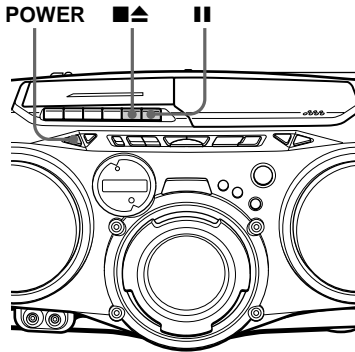

Tips

- Adjusting the volume or the audio emphasis (see page 18) will not affect the recording level.
- For the best results, use the AC power as a power source.
- To erase a recording, proceed as follows:
 - 1 Insert the tape whose recording you want to erase.
 - 2 Press ||.
 - 3 Press ▶.
 - 4 Press ●.
 - 5 Press ||.

To	Press
stop recording	■▲
pause recording	 Press the button again to resume recording.
turn on/off the player	POWER

Using the display

You can check information about the CD using the display.

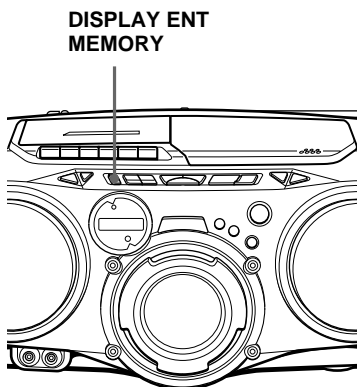

Checking the total track number and playing time

Press DISPLAY ENT•MEMORY in stop mode.

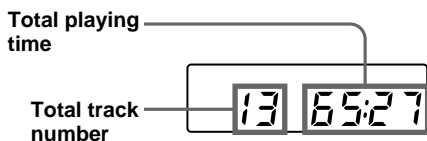

Checking the remaining time

Press DISPLAY ENT•MEMORY while playing a CD.

To display	Press DISPLAY ENT•MEMORY
the current track number and remaining time on the current track*	once
the number of tracks left and remaining time on the CD	twice
the current track number and playing time	three times

* For a track whose number is more than 20, the remaining time appears as “--:--”.

Locating a specific track

You can quickly locate any track on a CD using the number buttons on the remote.

You can also find a specific point in a track while playing a CD.

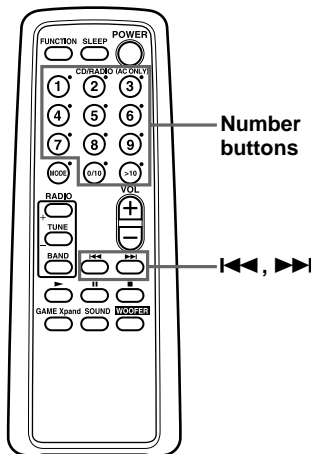

To locate	Press
a specific track directly	the number button of the track.
a point while listening to the sound	▶▶▶ (forward) or ◀◀◀ (backward) while playing and hold down until you find the point.
a point while observing the display	▶▶▶ (forward) or ◀◀◀ (backward) in pause and hold down until you find the point.

Note

You cannot locate a specific track if “SHUF” or “PGM” is lit in the display. Turn off the indication by pressing ■.

Tip

When you locate a track numbered over 10, press >10 first, then the corresponding number buttons. Example: To play track number 23, press >10 first, then 2 and 3.

Playing tracks repeatedly (Repeat Play)

You can play tracks repeatedly in normal, shuffle or program play modes (see page 14).

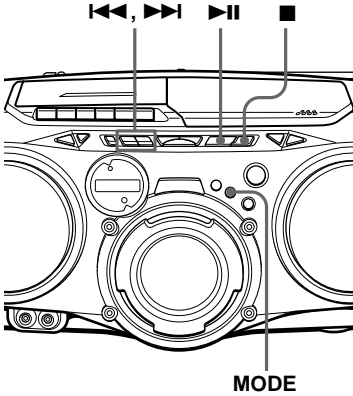

To cancel Repeat Play

Press MODE until “REP” disappears from the display.

On the remote

- Use ► instead of ►||.
- When you’ve selected “REP 1”, select the track by pressing the number buttons.

1 Press ■.
“Cd” appears in the display.

2 Proceed as follows.

To repeat	Do this
a single track	<ol style="list-style-type: none"> 1 Press MODE until “REP 1” appears. 2 Press ◀◀ or ▶▶ to select the track that you want to repeat. 3 Press ► .
all the tracks	<ol style="list-style-type: none"> 1 Press MODE until “REP ALL” appears. 2 Press ► .
tracks in random order	<ol style="list-style-type: none"> 1 Press MODE until “SHUF REP” appears. 2 Press ► .
programmed tracks	<ol style="list-style-type: none"> 1 Press MODE until “PGM REP” appears. 2 Program tracks (see step 3 on page 14). 3 Press ► .

Playing tracks in random order (Shuffle Play)

You can play tracks in random order.

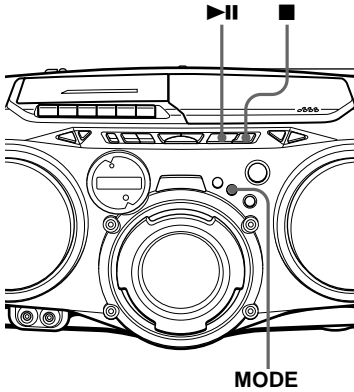

- 1 Press **■**.
"Cd" appears in the display.
- 2 Press **MODE** until "SHUF" appears in the display.
- 3 Press **▶||** to start shuffle play.

To cancel Shuffle Play
Press **MODE** until "SHUF" disappears from the display.

On the remote
Use **▶** instead of **▶||**.

Creating your own program (Program Play)

You can arrange the playing order of up to 20 tracks on a CD.

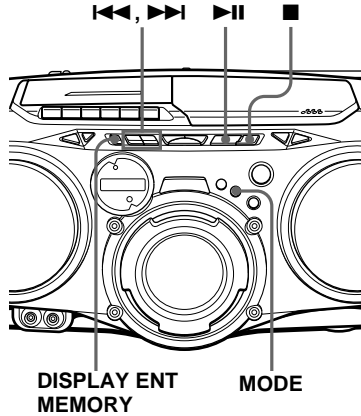

- 1 Press **■**.
"Cd" appears in the display.
- 2 Press **MODE** until "PGM" appears in the display.
- 3 Press the **◀◀** or **▶▶** to select the track you want to program, and press **DISPLAY ENT•MEMORY**.
Repeat this step.



Programed track **Playing order**

- 4 Press **▶||** to start program play.

On the remote

- 1 Press ■.
- 2 Press MODE until "PGM" appears in the display.
- 3 Press the number buttons for the tracks you want to program in the order you want.
- 4 Press ►.

To cancel Program Play

Press MODE until "PGM" disappears from the display.

To check the order of tracks before play

Press DISPLAY ENT•MEMORY.

Every time you press the button, the track number appears in the programmed order.

To change the current program

Press ■ once if the CD is stopped and twice if the CD is playing. The current program will be erased. Then create a new program following the programming procedure.

Tips

- You can play the same program again, since the program is saved until you open the CD compartment.
- You can record your own program. After you've created the program, insert a blank tape and press ● to start recording.

Presetting radio stations

You can store radio stations into the player's memory. You can preset up to 30 radio stations, 20 for FM and 10 for AM in any order.

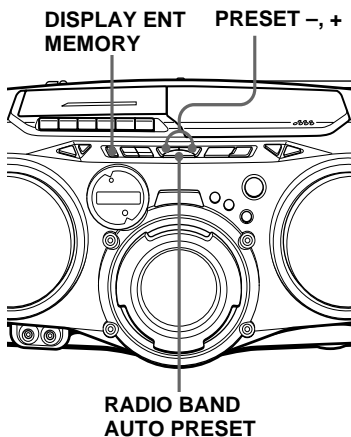

- 1** Press **RADIO BAND•AUTO PRESET** to select the band.
- 2** Hold down **RADIO BAND•AUTO PRESET** for 2 seconds until “**AUTO**” flashes in the display.
- 3** Press **DISPLAY ENT•MEMORY**.
The stations are stored in memory from the lower frequencies to the higher ones.

If a station cannot be preset automatically

You need to preset a station with a weak signal manually.

- 1** Press **RADIO BAND•AUTO PRESET** to select the band.
- 2** Tune in a station you want.
- 3** Hold down **DISPLAY ENT•MEMORY** for 2 seconds.
- 4** Press **PRESET +** or **-** until the preset number you want the new station on flashes in the display.
- 5** Press **DISPLAY ENT•MEMORY**.
The new station replaces the old one.

On the remote

- 1** Press **BAND** until the band you want appears in the display.
- 2** Press **TUNE +** or **-** until you tune in the station you want.
- 3** Hold down the number button that you want to preset the new station on for 2 seconds.
To select the preset number over 10, press **>10** first, then the corresponding number buttons. You need to hold down the last number button to enter for about 2 seconds. (Example: To select 12, press **>10** and **1** first, then hold down **2** for about 2 seconds.)

Playing preset radio stations

Once you've preset the stations, use PRESET + or – on the player or the number buttons on the remote to tune in to your favorite stations.

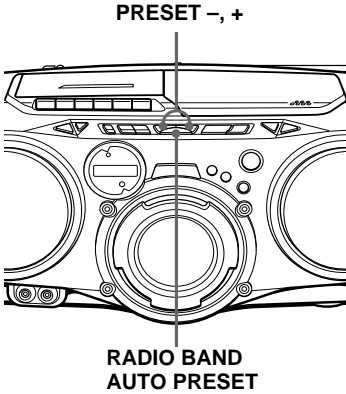

On the remote

- 1 Press BAND until the band you want appears in the display.
- 2 Press the number button to tune in a stored station.

To tune in a preset station over 10, press >10 first, then the corresponding number buttons. (Example: To tune in a preset station 12, press >10 and 1 first, and then press 2.)

- 1 Press RADIO BAND•AUTO PRESET to select the band.
- 2 Press PRESET + or – to tune in the stored station.

FM-05



ST FM 89.2

Selecting the audio emphasis (SOUND/POWER DRIVE WOOFER/GAME Xpand)

You can adjust the audio emphasis of the sound you are listening to. You can also enjoy the live presence sound from a game machine, etc., using the GAME Xpand button.

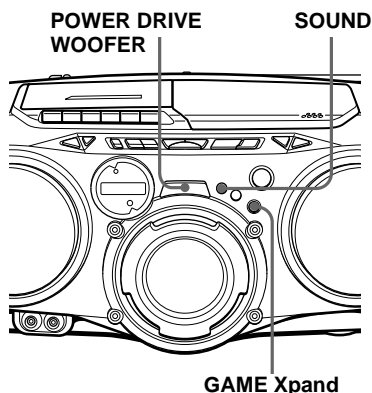

Selecting the sound characteristic

Press SOUND repeatedly to select the audio emphasis you want.

Choose	To get
	powerful, clean sounds, emphasizing low and high range audio
	light, bright sounds, emphasizing high and middle range audio.
	percussive sounds, emphasizing bass audio.
	the presence of vocals, stressing middle range audio.
	the whole dynamic range for music such as classical music.

Reinforcing the bass sound

Press POWER DRIVE WOOFER to select or in the display. is more effective. When the POWER DRIVE WOOFER function works, the button lights up.

To return to normal sound, press the button until the indication disappears from the display.

On the remote
Press WOOFER.

Notes

- While the sleeping timer is on, the POWER DRIVE WOOFER button does not light, even if the POWER DRIVE WOOFER function works.
- When using the headphones, the POWER DRIVE WOOFER function does not work.

Getting the GAME Xpand effect

Press GAME Xpand to enjoy the live presence sound. When the GAME Xpand function works, the button lights up.

To return to normal sound, press the button again to turn it off.

Note

When using the headphones, the GAME Xpand function does not work.

Falling asleep to music

You can set the player to turn off automatically after 10, 20, 30, 60, 90, and 120 minutes, allowing you to fall asleep while listening to music.

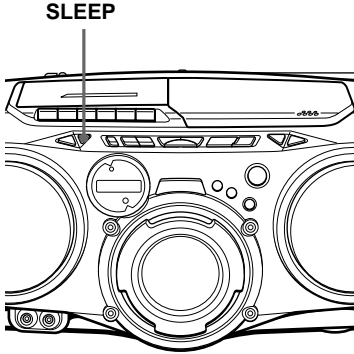

To cancel the sleep function
Press POWER to turn off the power.

Note

When you are playing a tape using this function:
If the tape length of one side is longer than the set time, the player will not go off until the tape reaches the end.

- 1 Play the music source you want.
- 2 Press SLEEP to display "SLEEP."
- 3 Press SLEEP to select the minutes until the player goes off automatically.
Each time you press the button, the indication changes as follows:
"60" → "90" → "120" → no indication → "10" → "20" → "30."



Choosing the power sources

You can use the AC power or batteries as a power source.

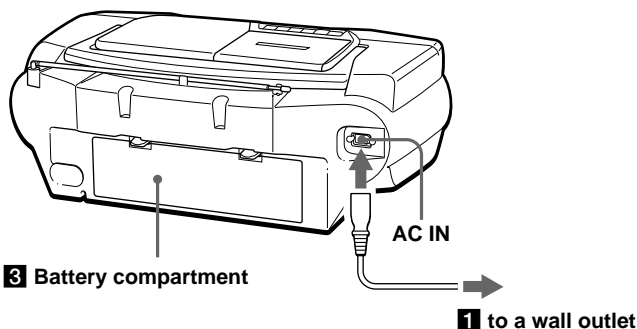

- 1** Connecting the AC power cord
Insert one end of the supplied AC power cord to the AC IN socket located at the rear of the player, and the other end to the wall outlet.

- 2** Inserting batteries into the remote

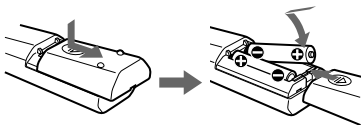

Insert two size AA (R6) batteries (not supplied)

Replacing batteries

With normal use, the batteries should last for about six months. When the remote no longer operates the player, replace all the batteries with new ones.

- 3** Using the player on batteries
Insert eight size D (R20) batteries (not supplied) into the battery compartment. To use the player on batteries, disconnect the AC power cord from the player.

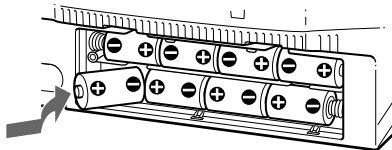

Replacing batteries

Replace the batteries when the OPR/BATT indicator dims or when the player stops operating. Replace all the batteries with new ones.

Notes

- Before you replace the batteries, be sure to take out the CD from the player.
- When you operate the player with the batteries, you cannot turn on the player with the remote.

Connecting a game machine or other optional components

You can enjoy the sound from a game machine or TV, etc. through the speakers of this player.

Be sure to turn off the power of each component before making connections. For details, refer to the instructions of the component to be connected.

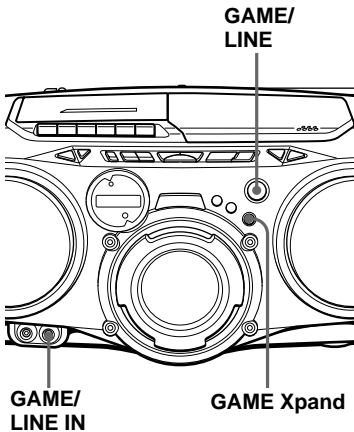

Connecting a game machine

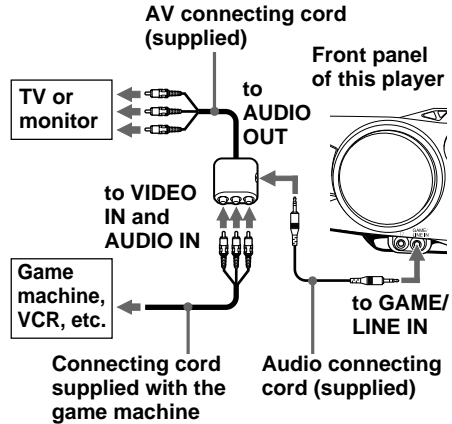

- 1 Connect the supplied AV connecting cord to the game machine and the TV or monitor.
- 2 Connect the supplied audio connecting cord to the supplied AV connecting cord and the GAME/LINE IN jack of this player.
- 3 Press GAME/LINE until "GAME LI" appears in the display.
- 4 Start the operation of the game machine.
- 5 Press GAME Xpand to get the GAME Xpand effect.

Note

When the supplied audio connecting cord is connected to the supplied AV connecting cord, you cannot listen to the sound from the TV or monitor.

continued

Connecting a game machine or other optional components
(continued)

Connecting a TV or a VCR

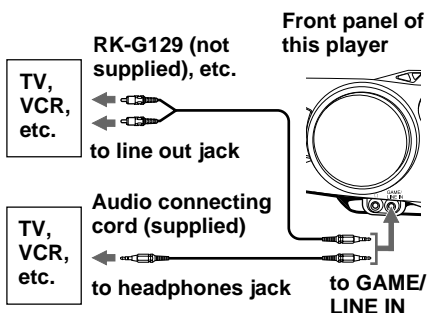

After finishing the connections, turn on the player, and press GAME/LINE to display "GAME LI".

Note

Connect the cords firmly to avoid any malfunction.

Recording the sound from the connected components

- 1 Insert a blank tape.
- 2 Press GAME/LINE to display "GAME LI".
- 3 Press ●.
Recording starts.
- 4 Play the optional component connected to the GAME/LINE IN jack of the player.

Precautions

On safety

- As the laser beam used in the CD player section is harmful to the eyes, do not attempt to disassemble the casing. Refer servicing to qualified personnel only.
- Should any solid object or liquid fall into the player, unplug the player, and have it checked by qualified personnel before operating it any further.
- Discs with non-standard shapes (e.g., heart, square, star) cannot be played on this player. Attempting to do so may damage the player. Do not use such discs.

On power sources

- For AC operation, use the supplied AC power cord; do not use any other type.
- The player is not disconnected from the AC power source (mains) as long as it is connected to the wall outlet, even if the player itself has been turned off.
- Unplug the player from the wall outlet when it is not be used for an extended period of time.
- For battery operation, use eight size D (R20) batteries.
- When the batteries are not to be used, remove them to avoid damage that can be caused by battery leakage or corrosion.
- The nameplate indicating operating voltage, power consumption, etc. is located at the bottom.

On placement

- Do not leave the player in a location near heat sources, or in a place subject to direct sunlight, excessive dust or mechanical shock.
- Do not place the player on an inclined or unstable place.
- Do not place anything within 10 mm of the side of the cabinet. The ventilation holes must be unobstructed for the player to operate properly and prolong the life of its components.
- If the player is left in a car parked in the sun, be sure to choose a location in the car where the player will not be subjected to the direct rays of the sun.
- Since a strong magnet is used for the speakers, keep personal credit cards using magnetic coding or spring-wound watches away from the player to prevent possible damage from the magnet.

On operation

- If the player is brought directly from a cold to a warm location, or is placed in a very damp room, moisture may condense on the lens inside the CD player section. Should this occur, the player will not operate properly. In this case, remove the CD and wait about an hour for the moisture to evaporate.
- If the player has not been used for a long time, set it in the playback mode to warm it up for a few minutes before inserting a cassette.

If you have any questions or problems concerning your player, please consult your nearest Sony dealer.

continued

Precautions (continued)

Notes on CDs

- Before playing, clean the CD with a cleaning cloth. Wipe the CD from the center out.



- Do not use solvents such as benzene, thinner, commercially available cleaners or anti-static spray intended for vinyl LPs.
 - Do not expose the CD to direct sunlight or heat sources such as hot air ducts, nor leave it in a car parked in direct sunlight as there can be a considerable rise in temperature inside the car.
 - Do not stick paper or sticker on the CD, nor scratch the surface of the CD.
 - After playing, store the CD in its case.
- If there is a scratch, dirt or fingerprints on the CD, it may cause tracking error.

Notes on cassettes

- Break off the cassette tab from side A or B to prevent accidental recording. If you want to reuse the tape for recording, cover the broken tab with adhesive tape.

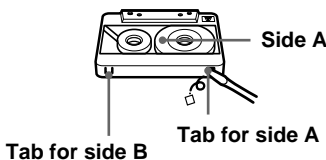

- The use of a cassette with more than 90 minutes of play time is not recommended except for long, continuous recording or playback.

Troubleshooting

General

The power is not on.

- Connect the AC power cord to the AC IN socket and a wall outlet securely.
- Make sure the batteries are inserted correctly.
- You cannot turn on the player with the remote when you operate the player on batteries.

The power is not on, and “bAttErY” and “Error” are displayed alternately.

- Make sure the batteries are inserted correctly.
- Replace all the batteries with new ones if they are weak.

There is no audio.

- Unplug the headphones when listening through speakers.

The power is turned off unexpectedly.

- Replace all the batteries with new ones.

Unusual sound is heard.

The sound is noisy, weak or has poor quality.

- Replace all the batteries with new ones if they are weak.

Noise is heard.

- Someone is using a portable telephone or other equipment that emits radio waves near the player.
→ Move the portable telephone, etc., away from the player.

CD Player

“no diSC” lights in the display even when a CD is in place.

- Place the CD with the label surface up.
- The CD-R/CD-RW was not finalized. Finalize the CD-R/CD-RW with the recording device.
- There is a problem with the quality of the CD-R/CD-RW, recording device, or application software.

The CD does not play.

- Place the CD with the label surface up.
- Clean the CD.
- Take out the CD and leave the CD compartment open for about an hour to dry moisture condensation.

The sound drops out.**Noise is heard**

- Reduce the volume.
 - Clean the CD, or replace it if the CD is badly damaged.
 - Place the player in a location free from vibration.
 - The sound may drop out or noise may be heard when using poor quality CD-Rs/CD-RWs or if there is a problem with the recording device or application software.
-

Radio

The audio is weak or has poor quality.

- Replace all the batteries with new ones if they are weak.
 - Move the player away from the TV.
 - If you are using the remote while listening to AM radio, noise may be heard. This is unavoidable.
-

The picture of your TV becomes unstable.

- If you are listening to an FM program near the TV with an indoor antenna, move the player away from the TV.
-

Tape Player

The tape does not move when you press an operation button.

- Close the tape compartment securely.
-

The REC ● button does not function.**The tape does not play.**

- Make sure the safety tab on the cassette is in place.
-

The tape does not erase completely.

- Clean the erasing head (see page 26).
 - Replace all the batteries with new ones if they are weak.
 - The source which was recorded on TYPE II (high position) or TYPE IV (metal) tape using this unit is being played. Record on TYPE I (normal) tape and play.
-

The tape does not record.

- Make sure the tape is inserted properly.
 - Make sure the safety tab of the cassette is in place.
-

The audio is weak.**The audio quality is poor.**

- Clean the heads, pinch roller and capstan (see page 26).
 - Demagnetize the heads using a demagnetizer (see page 26).
-

The sound is distorted.

- The TYPE II (high position) or TYPE IV (metal) tape is being used. Use TYPE I (normal) tape only.
-

Remote

The remote does not function.

- Replace all the batteries in the remote with new ones if they are weak.
 - Make sure that you are pointing the remote at the remote sensor on the player.
 - Remove any obstacles in the path of the remote and the player.
 - Make sure the remote sensor is not exposed to strong light such as direct sunlight or fluorescent lamp light.
 - Move closer to the player when using the remote.
-

After trying the above remedies, if you still have problems, unplug the AC power cord and remove all the batteries. After all the indications in the display disappear, plug the power cord and insert the batteries again. If the problem persists, please consult your nearest Sony dealer.

Maintenance

Cleaning the lens

If the lens becomes dirty, it may cause a skipping of sound during CD operation. Clean with a commercially available blower.

Cleaning the tape heads and tape path

Wipe the heads, the pinch roller and the capstan with a cleaning swab slightly moistened with cleaning fluid or alcohol after every 10 hours of operation for optimum playback and recording quality. To make the best possible recording, however, we recommend that you clean all surfaces over which tape travels before each recording.

Demagnetizing the tape heads

After 20 to 30 hours of use, enough residual magnetism will have built up on the tape heads to begin to cause loss of high frequency sound and hiss. At this time, you should demagnetize the heads and all metal parts in the tape path with a commercially available tape head demagnetizer.

Cleaning the cabinet

Clean the cabinet, panel and controls with a soft cloth slightly moistened with a mild detergent solution. Do not use any type of abrasive pad, scouring powder, or solvent, such as alcohol or benzine.

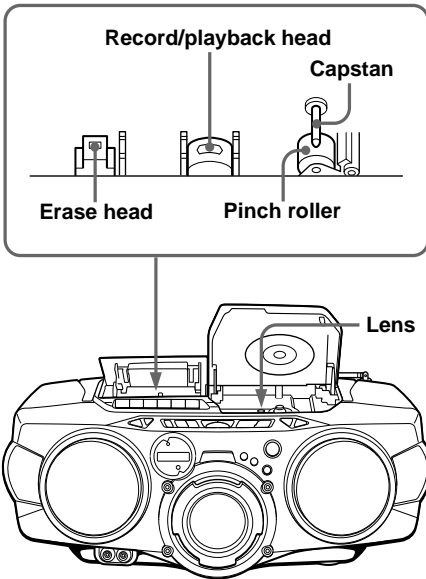

After cleaning, insert a tape when the areas cleaned are completely dry.

Specifications

AUDIO POWER SPECIFICATIONS

POWER OUTPUT AND TOTAL HARMONIC DISTORTION

Main speaker with 3.2-ohm loads, both channels driven from 1 000 - 10 000 Hz; rated 3 W per channel-minimum RMS power, with no more than 10 % total harmonic distortion in AC operation. Subwoofer with 4-ohm loads, driven at 50 - 150 Hz; rated 6 W minimum RMS power, with no more than 10 % total harmonic distortion in AC operation.

GAME Xpand with 12-ohm loads, driven at 3 000 - 10 000 Hz; rated 1 W per channel minimum RMS power, with no more than 10 % total harmonic distortion in AC operation.

Other Specifications

CD player section

System

Compact disc digital audio system

Laser diode properties

Material: GaAlAs

Wave length: 780 nm

Emission duration: Continuous

Laser output: Less than 44.6 μ W

(This output is the value measured at a distance of about 200 mm from the objective lens surface on the optical pick-up block with 7 mm aperture.)

Spindle speed

200 r/min (rpm) to 500 r/min (rpm) (CLV)

Number of channels

2

Frequency response

20 - 20 000 Hz +1/-2 dB

Wow and flutter

Below measurable limit

Radio section

Frequency range

FM: 87.6 - 108 MHz

AM: 530 - 1 710 kHz

Antennas

FM: Telescopic antenna

AM: Built-in ferrite bar antenna

Cassette-corder section

Recording system

4-track 2 channel stereo

Fast winding time

Approx. 120 sec. with Sony cassette C-60

Frequency response

TYPE 1 (normal): 70 - 13 000 Hz

General

Speakers

Main speaker: 10 cm (4 in.) dia., 3.2 Ω , cone type (2)

Subwoofer: 8 cm (3 ¼ in.) dia., 4 Ω , cone type (1)

GAME Xpand: 5 cm (2 in.) dia., 12 Ω , cone type (2)

Inputs

LINE IN jack (stereo minijack): sensitivity 436 mV

Outputs

Headphones jack (stereo minijack): for 16 - 68 Ω impedance headphones

Power output

Main speaker: 4 W + 4W (at 3.2 Ω , 10 % harmonic distortion in DC operation)

Subwoofer: 12 W (at 4 Ω , 10 % harmonic distortion in DC operation)

GAME Xpand: 1.2 W + 1.2 W (at 12 Ω , 10 % harmonic distortion in DC operation)

Power requirements

For CD radio cassette-corder:

120 V AC, 60 Hz

12 V DC, 8 size D (R20) batteries

For remote control:

3 V DC, 2 size AA (R6) batteries

Power consumption

AC 35 W

Battery life

For CD radio cassette-corder:

FM recording

Sony R20P: approx. 6.5 h

Sony alkaline LR20: approx. 18 h

Tape playback

Sony R20P: approx. 1.5 h

Sony alkaline LR20: approx. 6 h

CD playback

Sony R20P: approx. 1 h

Sony alkaline LR20: approx. 4 h

Dimensions

Approx. 530 × 195 × 342 mm (w/h/d)

(20 ⅞ × 7 ¾ × 13 ½ inches) (incl. projecting parts)

Mass

Approx. 7.4 kg (16 lb. 5 oz) (incl. batteries)

Supplied accessories

AC power cord (1)

Remote control (1)

AV connecting cord (1)

Audio connecting cord (1)

Design and specifications are subject to change without notice.

Optional accessories

Sony MDR headphones series

Index

A

Audio emphasis 18

B

Batteries

for player 20

for remote 20

C

CD player 12

Choosing power sources 20

Cleaning

cabinet 26

tape heads and tape path
26

Connecting

AC power cord 20

Optional components 21

Creating your own program 14

D, E, F

Demagnetizing the tape heads
26

Display 12

G, H

GAME Xpand 18

I, J, K

Improving broadcast reception
7

L, M, N, O

Listening to the radio 6

Locating a specific track 12

P, Q

Playing

a CD 4

a tape 8

preset radio stations 17

tracks repeatedly 13

POWER DRIVE WOOFER 18

Power sources 20

Presetting radio stations 16

Program Play 14

R

Radio stations

playing 17

presetting 16

Recording on a tape 10

Repeat Play 13

S

Selecting

audio emphasis 18

tracks 5

Setting up 20

Shuffle Play 14

SOUND 18

T

Timer

Falling asleep to music 19

Troubleshooting 24

U, V, W, X, Y, Z

Using the display 12